

WOODEN REELS FOR CABLES

KABELTROMMELN AUS MASSIVHOLZ



Currently 5 nailing lines are able to produce up to 150,000 of 400mm - 4000mm diameter flanges every month. In addition to flanges, are supplied barrel lags and flat pack Reel kits for self assembly.

All metal parts (plates, tie-rods, etc.) can be included with the flanges.

Fertigungslinien zur Herstellung von Kabeltrommelflanschen aus Massivholz mit einem Durchmesser von 400 bis 4000mm ermöglichen einen Ausstoss bis zu 150000 Stück/Monat. Zur Komplettierung können die Kernleisten und alle Metallteile (Trommelbolzen und Buchsen) mitgeliefert werden.



WOODEN REELS FOR CABLES
KABELTROMMELN AUS MASSIVHOLZ

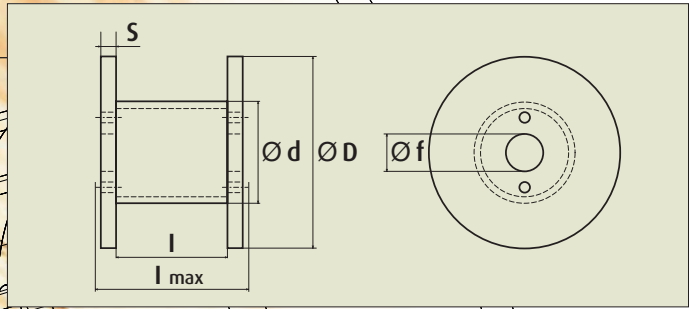

TYPE	D	d	l	l max	s	Ø f	Reel Volume (dm ³)	Capacity (kg)
TU26	26" (660 mm)					3 1/8"		
TU28	28" (711 mm)	11"	21"	22 1/2"	2 x 3/4"	3 1/8"	10930	530
TU30	30" (762 mm)	12"	18"	19 1/2"	2 x 3/4"	3 1/8"	10682	530
TU30	30" (762 mm)	15"	28"	29 1/2"	2 x 3/4"	3 1/8"	14837	720
TU32	32" (813 mm)	12"	24"	25 1/2"	2 x 3/4"	3 1/8"	16579	810
TU34	34" (864 mm)	17"	24"	25 1/2"	2 x 3/4"	3 1/8"	16334	810
TU34	34" (864 mm)	14"	26"	27 1/2"	2 x 3/4"	3 1/8"	19594	960
TU36	36" (914 mm)	17"	28"	29 1/2"	2 x 3/4"	3 1/8"	22134	1100
TU36	36" (914 mm)	17"	24"	25 1/2"	2 x 3/4"	3 1/8"	18972	950
TU36	36" (914 mm)	18"	22"	23 3/4"	2 x 7/8"	3 1/8"	16786	810
TU40	40" (1016 mm)	17"	24"	25 1/2"	2 x 3/4"	3 1/8"	24699	1200
TU42	42" (1068 mm)	18"	26"	27 3/4"	2 x 7/8"	3 1/8"	29390	1450
TU42	42" (1068 mm)	18"	28"	29 3/4"	2 x 7/8"	3 1/8"	31651	1500
TU45	45" (1143 mm)	21"	28"	29 3/4"	2 x 7/8"	3 1/8"	34816	1700
TU48	48" (1219 mm)	24"	25"	27"	2 x 1"	3 1/8"	33912	1600
TU48	48" (1219 mm)	24"	28"	30"	2 x 1"	3 1/8"	37981	1800
TU50	50" (1270 mm)	24"	32"	33 3/4"	2 x 7/8"	3 1/8"	48331	2300
TU54	54" (1372 mm)	24"	32"	33 3/4"	2 x 7/8"	3 1/8"	58781	2800
TU58	58" (1473 mm)	27"	30"	32 1/2"	2 x 1 1/8"	3 1/8"	62054	3000
TU66	66" (1676 mm)	30"	32"	35"	2 x 1 1/2"	3 1/8"	69231	3100
TU79	79" (2001 mm)	43 1/8"	25"	27"	2 x 1"	3 1/8"	85982	3200
TU79	79" (2001 mm)	43 1/8"	39"	41"	2 x 1"	3 1/8"	134131	5100

TYPE	D (mm)	d (mm)	l (mm)	l max (mm)	s (mm)	Ø f (mm)	Reel Volume (dm ³)	Capacity (kg)
TA06	630	315	335	415	34, 38, 46	82	78	250
TA07	710	355	420	500	34, 38, 46	82	125	400
TA08	800	400	470	550	34, 38, 46	82	177	600
TA09	900	450	470	575	46, 50	82	224	900
TA10	1000	500	580	685	46, 50	82	342	1300
TA12	1250	630	530	660	50, 64	82	577	1700
TA14	1400	710	750	880	50, 64	82	858	2500
TA16	1600	900	900	1055	64, 76	82	1237	3300
TA18	1800	1120	1140	1310	76, 84	82	1778	4500
TA20	2000	1250	1140	1310	76, 84	128	2182	5000
TA22	2240	1400	1140	1310	76, 84	128	2738	5600
TA25	2450	1500	1140	1310	76, 84	128	3360	6200

